

PRODUCT SCRAPBOOK

Don't enter the exhibit hall without checking out Ortho Tribune's guide to the products that are in there.

► page 4



PLAY IN THE CLOUDS

Edge software makes backing up your most important info both safe and secure.

► page 6



TECHNOLOGICAL ADVANCES

Do it all — from diagnostics to orthodontic treatment planning — with this new software.

► page 8



Out and about in Oahu

Welcome to Hawaii!

Now that most of us have flown here, from across the country or even from across the world, you don't want to miss this opportunity to see the best of what Hawaii and Oahu have to offer. And with the exhibit hall doors closing each day at 3:30 p.m., it leaves plenty of time to get out and explore Oahu.

With Waikiki as a central hub, you can explore the legendary North Shore one day and spend the next on the east side snorkeling at Hanauma Bay, a protected marine sanctuary with tons of colorful fish. Thrill seekers can skydive at Moku-leia while daydreamers can relax peacefully on the beach.

Here are some tips and activities to consider when exploring Oahu.

Traveling on Oahu

You can get around by car rental, shuttle, taxi or Oahu's public transportation sys-

► See OAHU, page 15



Photo/Provided by Hawaii Tourism Authority



A surfer takes on Oahu's North Shore. Photo/Hawaii Tourism Authority, Kirk Lee Aeder

Quench your thirst

This year's AAO annual meeting promises to satisfy your need for knowledge with expert lecturers and an array of companies showing off new technology

By Sierra Rendon, Managing Editor

The sun is shining, the water is beckoning, it's a beautiful day in Honolulu, and you're headed ... inside?

Yes, from at least 8 a.m. to 3:30 p.m., you're going to want to head inside the Honolulu Convention Center to get the most out of the American Association of Orthodontist's 112th annual meeting.

Nowhere else will you find the vast educational opportunities and C.E. opportunities aimed directly at orthodontists than this group's annual meeting, which is why thousands of orthodontists and

orthodontic staff make sure not to miss this educational program — even when the beaches of Waikiki are calling.

More than 160 clinicians and experts are here to speak on the most important trends, technologies and advance in orthodontics.

"We think that the exciting slate of speakers presenting during the next few days will satisfy your thirst for knowledge, while the relaxing environment will help you unwind and absorb the positive culture that permeates Hawaii," said Michael B. Rogers, DDS, AAO president, in the program guide.

It's also the perfect place to contemplate and make those big practice pur-

chases you've been thinking about all year. With more than 300 exhibiting companies on tap, you're sure to find everything you ever wanted and much more.

Education

Scientific lectures at the AAO will run the gamut from risk management to fundamentals to surgical considerations.

Here is just a small sampling of the extensive list of programs you may attend at the AAO:

- "The Role of Micro-implants in Surgi-

► See THIRST, page 2

← THIRST, Page 1

cal Orthodontics," with Hyo-Sang Park (8 a.m. Sunday)

- "Case Report: A Class II Malocclusion with TMD Symptoms," with Marissa Chu Keesler (1:55 p.m. Sunday)

- "The Enigma, Evidence, Efficacy, Efficiency and Clinical Outcomes of Class II Growth Modification in Modern Day Orthodontics: Is There Consensus?" with William A. Wiltshire (8:35 a.m. Monday)

- "Generalized Use of CBCT in Orthodontic Practice: Is This a Dream?" with Sercan Akyalcin (12:30 p.m. Monday)

- "Biomechanics of Root Resorption: Genetic Predisposition and Physiologic Balance," with Eugene Roberts (9:40 a.m. Tuesday)

In addition to the extensive schedule of scientific lectures for clinicians, there is also a complete schedule for orthodontic staff each day.

Even when the annual meeting ends on Tuesday, there are "post-conferences" Wednesday and Thursday in Maui, Oahu and Kauai. For more information, check with the registration desk.

Shuttle schedule

The AAO shuttles will operate at 15-minute intervals in the mornings from 6 a.m. to 9 a.m. and late afternoons from 1 p.m. to 3:30 p.m.; and at 30-minute intervals from 9 a.m. to 1 p.m.

Please refer to the shuttle signage that will be posted in each shuttle hotel for hours of operation and special event details. Routing and pickup locations are subject to change.

Mobile technology

The 2012 Annual Session iPhone application and mobile Internet browser for other smart phones is available. View session details, create your own agenda, network with other attendees, complete session evaluations, view exhibitor information and more.

First-time users will be asked to log in with their annual session registration confirmation numbers*, create profiles and select new passwords.

- To view the application on your phone, type in <http://mobile.aa02012.alliancetechnology.com> (Click on "My Agenda" to log into an existing account or create a new account.)



Photo/Provided by Hawaii Tourism Authority

- iPhone users should visit the app store via their phones and search for AAO 2012.

* Your registration confirmation number and attendee service center login password can be found in your registration confirmation e-mail. The subject line of the confirmation is: Registration Confirmation — 2012 AAO Annual Session. Attendees who wish to use the mobile service but do not have a smart phone may rent an iPod Touch on-site.



Image courtesy of Dr. Earl Broker.

Corrections

Ortho Tribune strives to maintain the utmost accuracy in its news and clinical reports. If you find a factual error or content that requires clarification, please report the details to Managing Editor Sierra Rendon at s.rendon@dental-tribune.com.

Tell us what you think!

Do you have general comments or criticism you would like to share? Is there a particular topic you would like to see articles about in Ortho Tribune? Let us know by e-mailing feedback@dentaltribune.com. We look forward to hearing from you! If you would like to make any change to your subscription (name, address or to opt out) please send us an e-mail at database@dental-tribune.com and be sure to include which publication you are referring to. Also, please note that subscription changes can take up to 6 weeks to process.

ORTHO TRIBUNE

PUBLISHER & CHAIRMAN

Torsten Oemus t.oemus@dental-tribune.com

CHIEF OPERATING OFFICER

Eric Seid e.seid@dental-tribune.com

GROUP EDITOR

Robin Goodman r.goodman@dental-tribune.com

EDITOR IN CHIEF ORTHO TRIBUNE

Prof. Dennis Tartakow
d.tartakow@dental-tribune.com

INTERNATIONAL EDITOR ORTHO TRIBUNE

Dr. Reiner Oemus r.oemus@dental-tribune.com

MANAGING EDITOR SHOW DAILIES

Kristine Colker k.colker@dental-tribune.com

MANAGING EDITOR ORTHO TRIBUNE

Sierra Rendon s.rendon@dental-tribune.com

MANAGING EDITOR

Fred Michmershuizen
fmichmershuizen@dental-tribune.com

MANAGING EDITOR

Robert Selleck, r.selleck@dental-tribune.com

ACCOUNT MANAGER

Gina Davison g.davison@dental-tribune.com

ACCOUNT MANAGER

Humberto Estrada h.estrada@dental-tribune.com

MARKETING MANAGER

Anna Kataoka-Wlodarczyk
a.wlodarczyk@dental-tribune.com

MARKETING & SALES ASSISTANT

Lorrie Young lyoung@dental-tribune.com

C.E. DIRECTOR

Christiane Ferret
c.ferret@dstudyclub.com

Dental Tribune America, LLC
116 West 23rd Street, Suite 500
New York, NY 10011
Phone (212) 244-7181
Fax (212) 244-7185

Published by Dental Tribune America
© 2012 Dental Tribune America, LLC
All rights reserved.

Dental Tribune strives to maintain the utmost accuracy in its news and clinical reports. If you find a factual error or content that requires clarification, please contact Managing Editor Sierra Rendon at s.rendon@dental-tribune.com.

Dental Tribune cannot assume responsibility for the validity of product claims or for typographical errors. The publisher also does not assume responsibility for product names or statements made by advertisers. Opinions expressed by authors are their own and may not reflect those of Dental Tribune America.

EDITORIAL BOARD

Jay Bowman, DMD, MSD (*Journalism & Education*)
Robert Boyd, DDS, MEd (*Periodontics & Education*)
Earl Broker, DDS (*T.M.D. & Orofacial Pain*)
Tarek El-Bialy, BDS, MS, MS, PhD
(*Research, Bioengineering & Education*)
Donald Giddon, DMD, PhD (*Psychology & Education*)
Donald Machen, DMD, MSD, MD, JD, MBA
(*Medicine, Law & Business*)
James Mah, DDS, MSc, MRCD, DMSc
(*Craniofacial Imaging & Education*)
Richard Masella, DMD (*Education*)
Malcolm Meister, DDS, MSM, JD (*Law & Education*)
Harold Middleberg, DDS (*Practice Management*)
Elliott Moskowitz, DDS, MSd (*Journalism & Education*)
James Mulick, DDS, MSD
(*Craniofacial Research & Education*)
Ravindra Nanda, BDS, MDS, PhD
(*Biomechanics & Education*)
Edward O'Neil, MD (*Internal Medicine*)
Donald Picard, DDS, MS (*Accounting*)
Howard Sacks, DMD (*Orthodontics*)
Glenn Sameshima, DDS, PhD (*Research & Education*)
Daniel Sarya, DDS, MPH (*Public Health*)
Keith Sherwood, DDS (*Oral Surgery*)
James Souers, DDS (*Orthodontics*)
Gregg Tartakow, DMD (*Orthodontics*) & Ortho
Tribune Associate Editor

AD

ORTHOVOICE®

Vegas Orthodontic International Conference & Exposition

Explore, Engage, Experience

LAS VEGAS OCT. 11-13 2012

visit orthovoice.com

Member Publication

AADE

American Association
of Dental Editors

Here at the AAO: What to know

What

American Association of Orthodontists' 112th Annual Session

When

Today through Tuesday

Where

Hawaii Convention Center, 1801 Kalakaua Ave., Honolulu

Online

www.aomembers.org/mtgs/2012-AAO-Annual-Session.cfm

Exhibit hall hours

The exhibit hall is located in Level 1 of the Honolulu Convention Center.

- 8 a.m.–3:30 p.m. today, Sunday and Monday
- 8 a.m.–2 p.m. Tuesday

Table clinics

7:30 a.m.–2:30 p.m. today, Sunday, Monday and Tuesday

Scientific posterboard exhibits

9-11 a.m. Sunday

Attire

The official dress code of the AAO is "Aloha Wear," which includes aloha shirts, khakis and loafers for men and aloha shirts, khakis, skirts, city shorts, dresses, loafers and sandals for women.

C.E. Pavilion

While attending the AAO, record the lectures you attend and print your C.E. hours report at the C.E. Pavilion on the Level 3 Breezeway.

Shuttle schedule

The AAO shuttles will operate at 15-minute intervals in the mornings from 6 a.m. to 9 a.m. and late afternoons from 1 p.m. to 3:30 p.m.; and at 30-minute intervals during mid-day from 9 a.m. to 1 p.m. every day.

The following hotels will have shuttle service: Hilton Hawaiian Village, Courtyard, Doubletree, Embassy Suites, Hilton Waikiki Beach, Hyatt Regency, Moana Surfrider, Royal Hawaiian, Sheraton Princess, Sheraton Waikiki and Waikiki Beach Marriott.

Please refer to the shuttle signage, which will be posted in each shuttle hotel, for hours of operation and special event details. Routing and pickup locations are subject to change.

Camp AAO

Children 6 months to 12 years old are welcome to participate in the Camp AAO on-site program. The activity center will be located at the Hawaii Convention Center, Room 321, and will be open daily.

Children ages 6 to 17 have the opportunity to participate in educational youth tours as well. The tours depart and return to the on-site activity center each day.

Those children participating in tours also have the option to sign up for hourly on-site attendance prior to and following the tour. An hourly rate will apply.

The youth tour program will include visits to Waikiki Aquarium, Honolulu Zoo, Bishop Museum, Dole Pineapple

Plantation and the Hawaii Children's Discovery Center.

Camp AAO activity center hours are from 6:30 a.m.–3 p.m. daily. Youth tour hours are 9 a.m.–12:30 p.m. daily.

For more information, visit www.accentregister.com/register/campAAO12 or call (504) 524-0188.

Professional lecture recordings

Most of the lectures presented at this conference will be audio recorded and available as a package set on a DVD ROM in MP3 format. Most of these recorded lectures will also include the speaker's screen presentation as an integrated synchronized file. On-site orders will be



The Hawaii Convention Center at night. Photo/Hawaii Tourism Authority, Chuck Painter

available for \$158 (includes shipping).

Giving back

Annual session attendees will have an opportunity to "give back" to the Honolulu community by aiding hungry resi-

dents of Oahu. The annual session "Virtual Food Bank" kiosk on Level 2 of the Convention Center will accept contributions and provide receipts for donations. All funds contributed will go to a local food bank.

Many adults have poorly aligned teeth and would like orthodontic treatment. The majority of these patients do not want to wear braces.

For over 20 years Myofunctional Research Co. (MRC) have developed orthodontic appliances to improve the dental and facial development of children, using myofunctional orthodontic techniques.

Due to increasing demand, the all new MYOBACE for Adults™ appliance system has been created. This is designed to correct orthodontic problems by assisting the treatment of the myofunctional causes and simultaneously aligning the teeth.

How it Works

- The appliances are made in the ideal arch form to assist in the correction of natural arch development by applying light forces to the anterior teeth.
- The extended lip bumper retrains overactive perioral musculature assisting lower anterior tooth alignment.
- The tongue tag trains the correct tongue position which indirectly expands the maxillary arch form.



Attend an MRC educational program where you can learn how to effectively incorporate these appliances into your practice.

Phone 1866 550 4696 www.myoresearch.com/courses

MYOFUNCTIONAL RESEARCH CO.
www.myoresearch.com
MRC Grow with us

Product scrapbook

Here is a look at some of the products you'll want to check out in the exhibit hall



Cloud9Ortho is the first true cloud-based orthodontic practice management software, which means no more servers. You can use Macs or PCs, have fast speed in your satellite offices and lower your IT cost. Stop by booth No. 239 for a free demo.

Photo/Provided by Cloud9Ortho



The 4-Part MiniScope by Specialty Appliances allows for greater opening and lateral movement while keeping the forces in the proper direction. Stop by booth No. 946 for more information.

Photo/Provided by Specialty Appliances



The GXDP-700 Series from Gendex starts with a digital panoramic system with sophisticated styling and an ergonomic design, including an advanced touchscreen interface. The GXDP-700 is a modular system, upgradable from 2-D panoramic to cephalometrics or 3-D cone beam with expandable field-of-views or both. Visit booth No. 4010 to learn more! Photo/Provided by Gendex

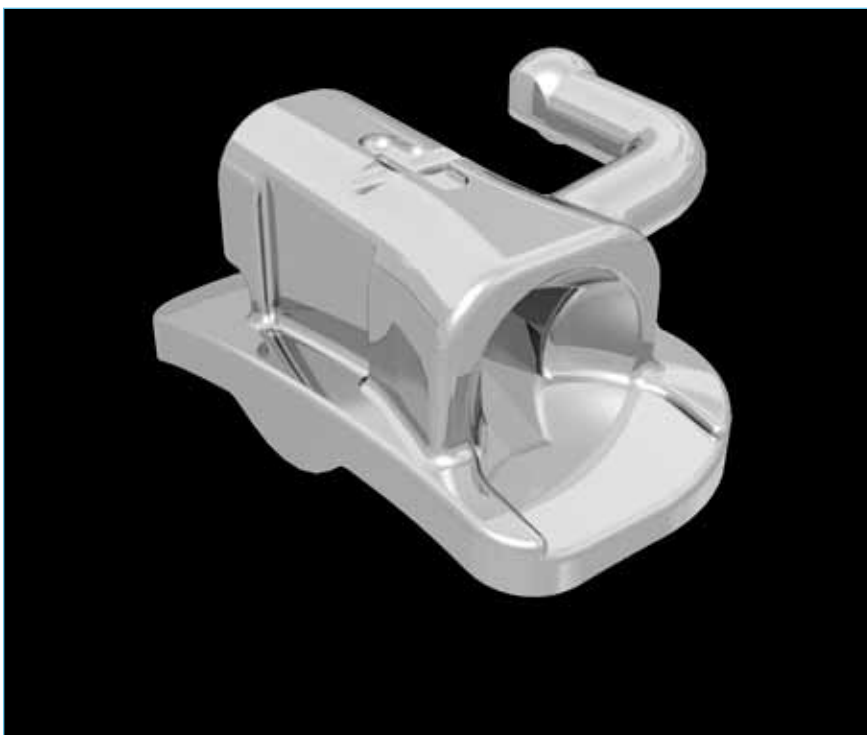

Visit Dentaureum at booth No. 1037 to see its new line of M-Series Buccal Tubes. These tubes feature a patented laser-structured bonding pad that is guaranteed to bond better than any other tube on the market or Dentaureum refunds your purchase at 150 percent! You can also call (800) 523-3946 or e-mail sales@dentaureum-us.com for more information.

Photo/Provided by Dentaureum



Stop by booth No. 547 to take a look at this digital 'SLR' camera with traditional ringlight or wireless ringflash. The camera also comes with a 90 mm macro lens with orthodontic settings. Photo/Provided by CliniPix

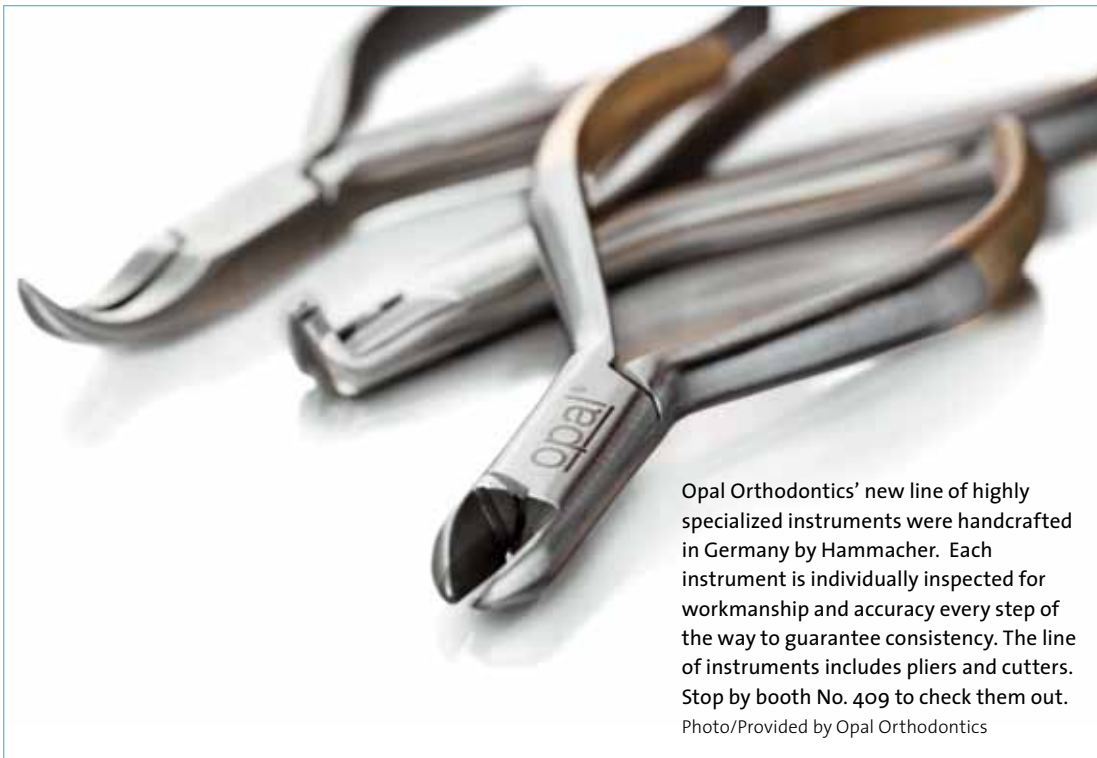

Opal Orthodontics' new line of highly specialized instruments were handcrafted in Germany by Hammacher. Each instrument is individually inspected for workmanship and accuracy every step of the way to guarantee consistency. The line of instruments includes pliers and cutters. Stop by booth No. 409 to check them out. Photo/Provided by Opal Orthodontics



Ortho Organizers is shifting the way you think about orthodontics. To limit extractions and turn difficult Class II cases into simpler Class I cases is a dream come true for you and your patients with the Carriere Distalizer Appliance. See the appliance at Ortho Organizers' booth, No. 1227. Photo/Provided by Ortho Organizers



Headquartered in Houston, Texas, ClearCorrect serves orthodontic industries by providing an affordable and doctor-friendly clear aligner system. No course is required. To send in a case, simply call and register at (888) 331-3323 with your new accounts specialist or visit ClearCorrect at booth No. 856. Photo/Provided by ClearCorrect

For a glove that feels in-existent and provides the maneuverability of a bare hand, take a look at Plak Smacker's newest gloves: the Ultra Thin Nitrile. The Ultra Thin Nitrile — part of Plak Smacker's new TruFit line — is a latex-free glove made with a soft nitrile material. This allows the glove to be used during appointments where the patient or clinician has a latex allergy. Free TruFit samples are available at booth No. 1847. They are available in seashell white in both 100-count and 200-count boxes. Photo/Provided by Plak Smacker



AD

A Better Bond. M SERIES **Guaranteed.**



M2



M1



M

See this product at Booth 1037

Guaranteed* Better Bond Or Get 150% Money Back!
(Refund limited to trial offer)

D

DENTAURUM

Dentaurum USA • 10 Pheasant Run • Newtown PA • 18940 • Phone: 800.523.3946 • Fax: 800.553.6389
www.dentaurum.com • sales@dentaurum-us.com

Edge combines management, imaging and communication



The Edge Dashboard.
Photo/Provided by Orthoz

Edge from Orthoz delivers an all-encompassing practice management, imaging and communication software with plenty of features, high capability and integrated programs — all supported by a customer service team. Edge features private Cloud Computing with off-site data hosting options, innovative imaging, reminders, patient-education animations and more.

With private, secure Cloud Computing

from Orthoz, your practice can eliminate the cost, complexity and risk associated with in-house servers and backups. This feature allows you to fully access the secure web-based data infrastructure from anywhere, even your smart phone.

- 35 percent to 44 percent cost savings with lower initial and ongoing hardware costs

- Secure data protected by world-class firewalls

Here at the AAO

For more information, contact Orthoz at (800) 678-4644 or by e-mail at sales@orthoz.com, go online to www.orthoz.com or stop by the booth, No. 2003.

- Reliable backups on multiple platforms

- Decreased risk of theft, vandalism and fire

- Two data access pathways: Internet or cell-based network

The design inside Edge uses the latest user interface innovations, such as navigation elements that present meaningful options, hover view and use of drag-and-drop, and Edge is backed by an industry-leading customer-support team.

Check out other advancements available with Edge.

- *Edge Imaging* is one of the most robust imaging technologies available today, according to Orthoz. With an intuitive interface, time-saving features and easy customization, Edge Imaging can help manage all of your patient image files.

Edge Imaging includes new features such as quick-access card flow presentation, smart drag-and-drop layout customization, unlimited undo capabilities, silhouette image alignment and more.

- *Premier Imaging* is an optional upgrade for Edge Imaging and includes comprehensive image morphing, cephal tracing and analysis and Bolton Standards. Superimpose multiple time points on structures rather than oriented planes or use Bolton Standards for no-trace quick review. There is no additional cost for a multi-user license or digital X-ray integration.

- *Edge Animations* are patient-education animations for improved compliance and case presentation, including surgical and 3-D animations. With Edge Animations, you have the ability to edit and customize videos, using annotation and audio controls or drag-and-drop, so virtually any image or movie can be included. Publish your animations to disc, e-mail or YouTube.

- *Edge Reminders* is an easy-to-use system for automating your patient reminders. Send automated phone, text and e-mail appointment reminders for any range of upcoming appointment dates, recall reminders, birthday greetings and more. Patient responses are even integrated into your schedule. Edge Reminders offers low, flat billing with no minimum monthly charge.

- *Edge Portal* offers 24/7 online account access for patients, responsible parties and consulting professionals to retrieve appropriate information and images, make online credit card payments and more.

Edge Portal also gives your practice real-time access to vital practice information, treatment chart data and images from any location or device, including tablets and smart phones.

AD

You know how important photographs are to your practice, but you don't know who to turn to for advice. PhotoMed understands your **needs** and can help you choose the right camera. We also include **a** support and loan equipment program for the life of the camera so you have someone to turn to if you have questions.

PhotoMed dental cameras feature the best digital camera equipment available. The Canon G12, Rebel T3 and T3i are great choices.

Choosing a quality **dental** system for your practice doesn't have to be difficult. Call the experts at PhotoMed and we'll help you with all of your **camera** questions.

PhotoMed www.photomed.net • 800.998.7765



Visit the PhotoMed booth at these upcoming meetings:

AAOD, Wash. DC - #100
CDA, Anaheim - #2034
AAO, Honolulu - #847
6 Month Smiles, Boston

Opal Orthodontics previews new VALO Ortho Cordless

Opal Orthodontics will preview its new VALO Ortho Cordless curing light this week at the 2012 AAO Annual Session here in Honolulu.

VALO Ortho Cordless follows suit with VALO Ortho, its expertly engineered counterpart, adding a battery-operated, cordless wand for mobility. Both lights maintain the powerfully efficient broadband technology that VALO has been awarded from notable dental organizations. VALO Ortho Cordless is designed for the orthodontist performing direct and indirect orthodontic procedures, who is seeking the quality, durability and power of VALO, now with the convenience of a cordless curing light.

The light features custom, multi-wavelength Light Emitting Diodes (LEDs) to produce high-intensity light at 395-480 nm — capable of polymerizing all light-cured dental materials quickly and efficiently.

VALO Ortho Cordless comes with VALO rechargeable batteries and a battery charger suitable for power outlets from 100 to 240 volts. The standard lithium iron phosphate rechargeable batteries are safe, inexpensive and

Here at the AAO

For more information, visit Opal Orthodontics' booth, No. 409. Opal Orthodontics will feature a daily VALO Ortho Cordless giveaway at its booth. You may also visit www.valo-led.com or call customer service at (888) 863-5883.

optimized for power and longevity. The new handpiece is designed to rest in a standard dental unit bracket, or it can

be custom-mounted using the bracket included in the kit. It offers consistent curing intensity and output in a durable, aerospace aluminum body with Teflon coating and a sleek, ergonomic design.

About Opal Orthodontics

Opal Orthodontics, a division of Ultradent Products, Inc., is committed to bringing new and innovative products to the orthodontic market. Opal Orthodon-

tics products include bands and brackets, archwires, adhesives, instruments, elastomers and homecare products designed to meet the demanding needs of today's orthodontics practices.

Opal Orthodontics is also a proud partner of Susan G. Komen for the Cure in its fight to eliminate breast cancer.

For more information about Opal Orthodontics, call (888) 863-5883 or visit www.opalorthodontics.com.



The VALO Ortho Cordless.
Photo/Provided by
Ortho Orthodontics

Ride the technology wave.

Sesame Communications offers an award-winning suite of patient communication and engagement tools exclusively for orthodontic practices.

- ✓ Websites & Mobile Sites
- ✓ Online Contests & Sweepstakes
- ✓ Social Media
- ✓ Search Engine Marketing
- ✓ Search Engine Optimization
- ✓ Secure Patient Login
- ✓ Automated Patient Reminders
- ✓ Online Bill Pay
- ✓ Smart Practice Analytics

Access real time analytics on practice operations, marketing effectiveness and patient satisfaction levels all from your website's own Sesame 24-7™ dashboard.

Sesame gives you, the practice CEO, everything you need to grow your practice and strengthen patient loyalty.



"We looked for a company to provide us with a strategic solution for maintaining our practice prominence in this new digital age, and Sesame proved to be the right partner for our practice."
— Dr. Andrew Orchin

Join us at the
2012 AAO
in Honolulu!
booth
#1927



Copyright © 2012 Sesame Communications, Inc. All rights reserved. The Sesame logo and Sesame 24-7 are trademarks of Sesame Communications.

Get started now!

866•530•7295

info@sesamecommunications.com
www.sesame24-7.com

Over 6 million people use Sesame to communicate with their dental providers.

Ortho Classic offers new marketing, design service

Founded in 1991, World Class Technology/Ortho Classic has quickly grown from strictly manufacturing orthodontic products for some of the industry's largest suppliers to a direct-to-doctor manufacturer and supplier.

During this growth, the company has placed further focus on offering industry-specific solutions and services from an in-house orthodontic laboratory to its newest service offering, OrthoAMP.

OrthoAMP is a marketing and design service primarily focused on helping orthodontic practices create innovative and cohesive multi-channel marketing assets. With strategic focus placed on advertising, marketing and practice building (or AMP), OrthoAMP services include many diversified solutions from professional print and web design solutions to promotional items and advertising.

Each and every project is custom-designed by graphic designers and marketing specialists who currently work in the orthodontic industry.

To best facilitate this new service, Ortho Classic has built a state-of-the-art marketing and graphic design and production room in the heart of its 60,000-square-foot manufacturing



Ortho Classic's state-of-the-art marketing and graphic design and production room in its 60,000-square-foot manufacturing headquarters in McMinnville, Ore.

Photo/Provided by Ortho Classic

headquarters in McMinnville, Ore.

Equipped with an in-house photo studio, wide format printer and a 25-foot, print-on-demand digital press, there are very few jobs the company can't handle.

"It just made sense for us," said Ortho Classic President Rolf Hagelganz of the new design and production room.

"Everything we do is based on vertical integration; we design and manufac-

Here at the AAO

For more information, contact Ortho Classic at (866) 752-0065 or visit its booth, No. 1603.

'The next logical step was to bring in the printing equipment for our graphic designers.'

ture our entire product line in-house, so the next logical step was to bring in the printing equipment for our graphic designers."

Ortho Classic aims to provide design and marketing expertise on projects of any size, making every effort to understand your practice's business needs and goals. Its team of marketing experts provide innovative solutions designed to draw attention and improve the visibility of your practice.

For more information, contact: Ortho Classic, OrthoAMP Service, 1300 NE Alpha Dr., McMinnville, Ore. 97128, (866) 752-0065.

CANON REBEL T3i DIGITAL CLINICAL CAMERA SYSTEM

The Canon Rebel T3i is the first Rebel model to include the ability to work with wireless flashes. This feature was previously reserved for higher end, professional cameras and allows the T3i to work with modern wireless macro flashes.

Doing away with the flash power pack and cord results in a lighter, more balanced camera. The Rebel T3i is an 18-megapixel digital camera that features an articulat-

ing LCD screen and a 1080p HD video mode.

PhotoMed offers two wireless flash options for the T3i as well as two traditional macro flashes and four macro lens options.

For more information or to see the Canon Rebel T3i for yourself, visit www.photomed.net, call (800) 998-7765 or stop by the PhotoMed booth, No. 847, here during the AAO Annual Session.

Photo/Provided by PhotoMed



PLANMECA ProMax 3D Mid



Photo/Provided by Patterson Dental

The new PLANMECA ProMax® 3D Mid is a CBVT all-in-one unit, including 3-D imaging, panoramic, extraoral bitewing and cephalometric, that can accommodate all of your clinical needs. The PLANMECA ProMax 3D Mid provides an extended selection of 3-D volume sizes combined with traditional 2-D panoramic and cephalometric imaging.

The unit has the unique ability to meet all of your diagnostic needs, including implantology, endodontics, periodontics and orthodontics, as well as dental and maxillofacial surgery and TMJ analysis.

The volume sizes range from ø3.4 by 4.2 cm to ø16 by 16 cm. This wide selection of volume sizes allows for optimizing the imaging area according to specific diagnostic task — always complying with the best practices of dentistry, including the ALARA (as low as reasonably achievable) principle, to minimize radiation.

For more information on the PLANMECA ProMax 3D Mid, stop by the Patterson Dental booth, No. 655, here during the AAO.

EDGE

ALL-VERSATILE
ALL-ENCOMPASSING
ALL-EDGE

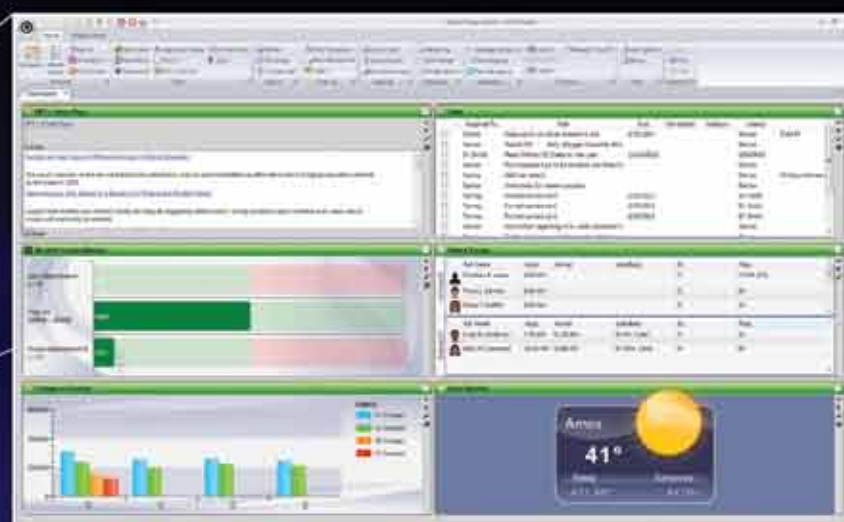

**Edge Practice Management System.
It's all you really need.**

Edge delivers the ideal all-comprehensive practice management, imaging, and communication software with robust features, unmatched capabilities, and integrated programs—which includes private and secure Edge Cloud Computing—all supported by a top-notch customer service team. Discover a world of efficiency, profitability, and innovation in your practice.

Above all, EDGE.

(800) 678-4644
sales@ortho2.com | www.ortho2.com

Practice Complete Management.



ORTHO2